

PRODUSELE SUNT FABRICATE DIN STICLĂ BOROSILICATĂ

ALL PRODUCTS MADE FROM BOROSILICATE GLASS

CARACTERISTICILE FIZICE ALE STICLEI

PHYSICAL CHARACTERISTICS OF GLASS

Coefficientul de dilatare α <i>Coefficient of expansion α</i>	20 - 300°C	K ⁻¹	3,2 x 10 ⁻⁷
Densitatea ρ <i>Density ρ</i>	20°C	g.cm ⁻³	2.23
Punct de transformare t_g <i>Transformation point t_g</i>	10 ^{13.2} dPas	°C	534
Temperatura maximă recomandată pentru utilizare <i>Recommended maximal usage temperature</i>		°C	500

CARACTERISTICILE CHIMICE ALE STICLEI

CHEMICAL CHARACTERISTICS OF THE GLASS

Componentele <i>Components</i>	Procent <i>% wight</i>
SiO ₂	>80%
B ₂ O ₃	13.0
Al ₂ O ₃	2.0
Na ₂ O+K ₂ O	4.5

REZISTENȚA CHIMICĂ A STICLEI BOROSILICATE

CHEMICAL RESISTANCE OF THE BOROSILICATE GLASS

Metoda acceptată conform ISO <i>Method according to norms ISO</i>	Valoare permisă <i>Permissable value</i>		Valoarea maximă admisă <i>Maximal value attained</i>	
	Clasa <i>Class</i>	Valoarea <i>Value</i>	Clasa <i>Class</i>	Valoarea <i>Value</i>
Rezistența față de apă la 98°C conform ISO 719 ($\mu\text{g.g}^{-1}$) <i>Resistence against water at 98°C, according to ISO 719($\mu\text{g.g}^{-1}$)</i>	HGB1	31	HGB1	25
Rezistența față de apă la 121°C conform ISO 720 ($\mu\text{g.g}^{-1}$) <i>Resistence against water at 121°C, according to ISO 720($\mu\text{g.g}^{-1}$)</i>	HGA1	62	HGA1	28
Rezistența față de acizi conform ISO 1776 ($\mu\text{g.dm}^2$) <i>Resistence against acids, according to ISO 1776($\mu\text{g.dm}^2$)</i>	1	100	1	10,9
Rezistența față de alcali conform ISO 695 ($\mu\text{g.dm}^2$) <i>Resistence against alkalis, according to ISO 695($\mu\text{g.dm}^2$)</i>	A2	175	A2	120

1101 PAHAR CILINDRIC GRADAT CU CIOC, FORMA JOASĂ

BEAKER LOW FORM WITH SPOUT AND GRADUATION

Capacity (ml)	O.D. (mm)	Height (mm)
50	42	60
100	51	70
150	60	80
200	65	88
250	70	95
300	75	102
400	80	110
500	87	118
600	90	125
800	100	135
1000	106	145
2000	132	185
3000	150	210
5000	178	280



1102 PAHAR CILINDRIC GRADAT CU CIOC, FORMA ÎNALTĂ

BEAKER TALL FORM WITH SPOUT AND GRADUATION

Capacity (ml)	O.D. (mm)	Height (mm)
50	40	67
100	45	88
150	53	100
250	60	122
400	70	138
600	80	165
800	90	178
1000	100	195

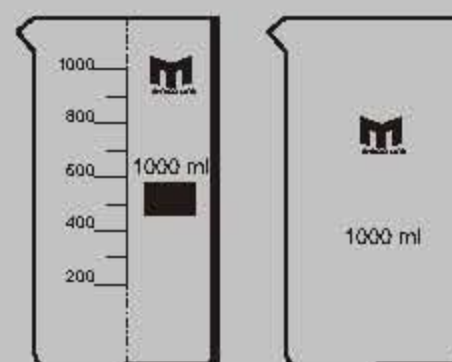

1111 BALON CU FUND PLAT CU GÂT ÎNGUST

BOILING FLASK, FLAT BOTTOM, LONG NARROW NECK

Capacity (ml)	O.D of neck (mm)	O.D. Of bulb (mm)	Height (mm)
50	20	53	100
100	21	65	120
150	22	76	140
200	23	83	150
250	25	88	160
300	26	92	170
500	30	110	200
1000	35	140	250

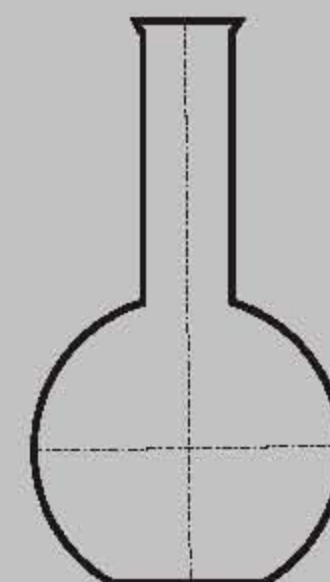

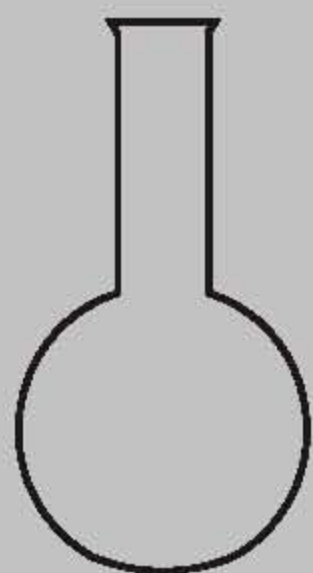

1115 BALON CU FUND ROTUND CU GÂT ÎNGUST

BOILING FLASK ROUND BOTTOM, LONG NECK

Capacity (ml)	O. D. of neck (mm)	O. D. of bulb (mm)	Height (mm)
50	20	53	100
100	21	65	120
150	22	76	145
200	23	83	155
250	25	88	165
300	26	92	180
500	30	110	210
1000	35	140	260
2000	46	175	305
3000	50	199	380
5000	55	235	415

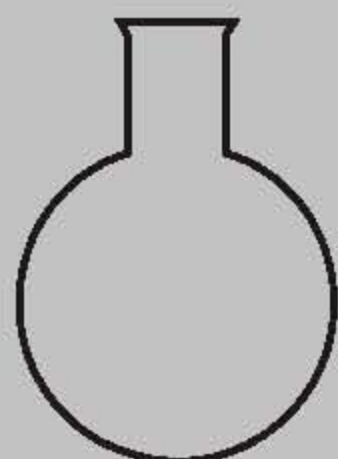

1117 BALON CU FUND ROTUND CU GÂT LARG

BOILING FLASK, ROUND BOTTOM, SHORT NECK

Capacity (ml)	O. D. of neck (mm)	O. D. of bulb (mm)	Height (mm)
250	30	86	120
500	40	110	160
1000	45	140	200
2000	50	175	250

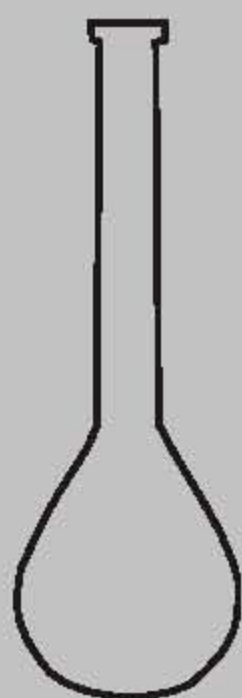

1118 BALON KJELDHAL

NITROGEN FLASK, ROUND BOTTOM, LONG NECK

Capacity (ml)	O. D. of neck (mm)	O. D. of bulb (mm)	Height (mm)
50	22	51	200
100	22	60	200
250	34	81	270
500	34	101	300
1000	34	126	350

1120 VAS CONIC GRADAT CU GURA LARGĂ

Capacity (ml)	O.D. of neck (mm)	O.D. of bulb (mm)	Height (mm)
50	34	51	85
100	34	64	105
200	50	79	131
250	50	85	140
300	50	87	156
500	50	105	175
1000	50	131	220
2000	72	153	275



1121 VAS CONIC GRADAT GURA ÎNGUSTĂ

BOILING FLASK, CONICAL

Capacity (ml)	O.D. of neck (mm)	O.D. of bulb (mm)	Height (mm)
50	22	51	85
100	22	64	105
150	28	71	120
200	34	77	132
250	34	85	140
300	34	89	153
500	34	105	175
1000	42	131	220
2000	50	166	280



1122 VAS CONIC CU DOP RODAT

CONICAL FLASK, WITH GROUND IN GLASS STOPPER

Capacity (ml)	O.D. of bulb (mm)	Height (mm)
50	50	90
100	60	108
250	83	140
500	98	185
1000	130	230



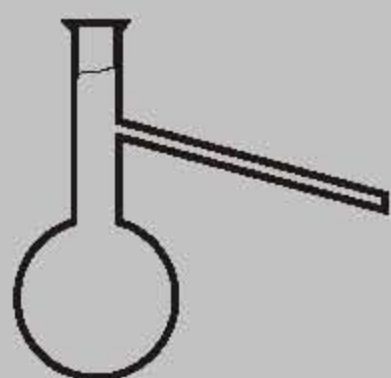

1131 BALON DE DISTILARE WÜRTZ

DISTILLING FLASK, WITH SIDE TUBE

Capacity (ml)	O.D. Of neck (mm)	O.D. of bulb (mm)	O.D. of side tube (mm)	Height (mm)
125	23	70	7.5	190
250	25	88	8	220
500	30	100	9	270
1000	35	140	10	350
2000	46	175	12	410

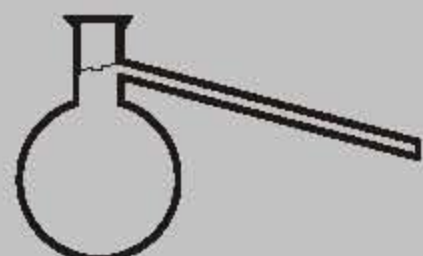

1132 BALON DE DISTILARE CHURCH

DISTILLING FLASK

Capacity (ml)	I.D. Of neck (mm)	O.D. of bulb (mm)	Height (mm)
300	22	86	131
500	24	102	135

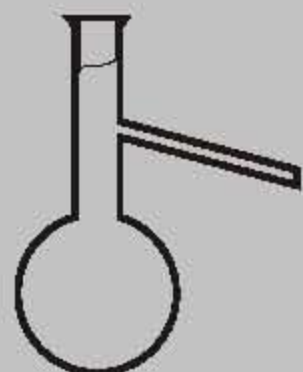

1133 BALON DE DISTILARE ENGLER

DISTILLING FLASK, WITH SIDE TUBE

Capacity (ml)	I.D. Of neck (mm)	O.D. of bulb (mm)	Height (mm)
100	17	65	215
125	17	69	215

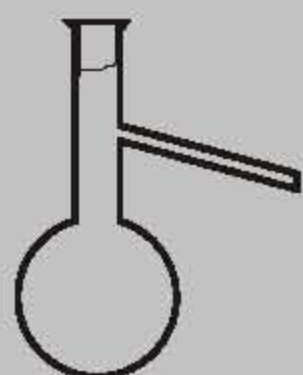

1134 BALON DE DISTILARE

DISTILLING FLASK, WITH SIDE TUBE

Capacity (ml)	O.D. Of neck (mm)	O.D. of bulb (mm)	Length of side tube (mm)	Height (mm)
250	17	86	100	215

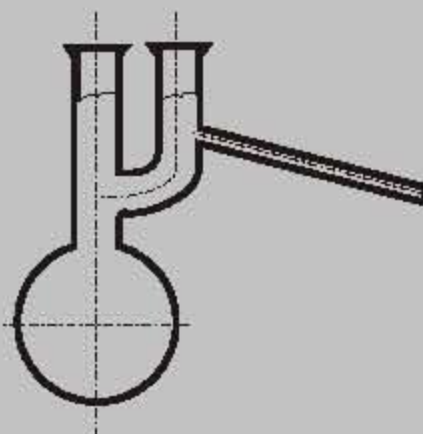

1135 BALON DE DISTILARE CLAISEN

BALLON OF DISTILARY CLAISEN

Capacity (ml)	O.D. Of neck (mm)	O.D. Of bulb (mm)	Height (mm)
125	23	70	190
250	25	88	220
500	30	110	270
1000	36	140	350
2000	46	175	410

1171

CAPSULĂ STICLĂ CU FUND PLAT

EVAPORATING DISH, FLAT BOTTOM

O.D. of top (mm)	Height (mm)
60	30
90	45
120	60
150	75

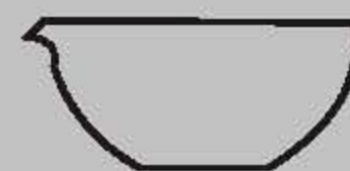

1172

CAPSULĂ STICLĂ CU FUND ROTUND

EVAPORATING DISH, ROUND BOTTOM

O.D. of top (mm)	Height (mm)
60	30
90	45
120	60
150	75



1173

CRISTALIZATOARE

CRISTALLIZING DISH, WITH SPOUT

O. D. (mm)	Height (mm)
60	40
90	45
100	50
125	63
150	75
180	90

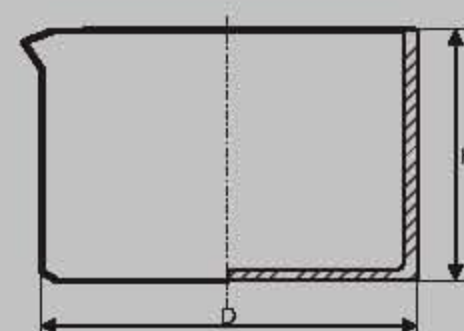

1175

STICLĂ CEAS

WATCH GLASS

Diameter
(mm)

45, 60, 70, 80, 90, 100, 120, 150, 180

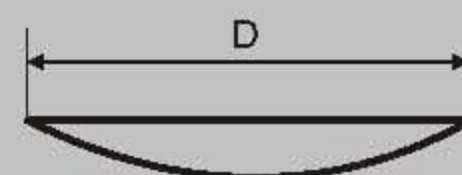

1177

CUTII PETRI

PETRI DISH

Cover dia (mm)	Bottom dia. (Mm)	Height (mm)
65	60	15
82	75	15
98	90	18
107	100	20
130	120	25
160	150	30

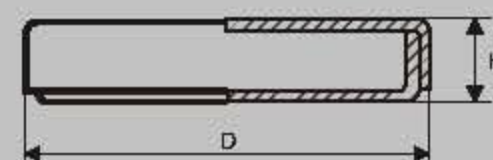

1207 COLOANĂ DE FRACTIONARE VIGREUX

DISTILLING TUBE, WITH THORN, VIGREUX

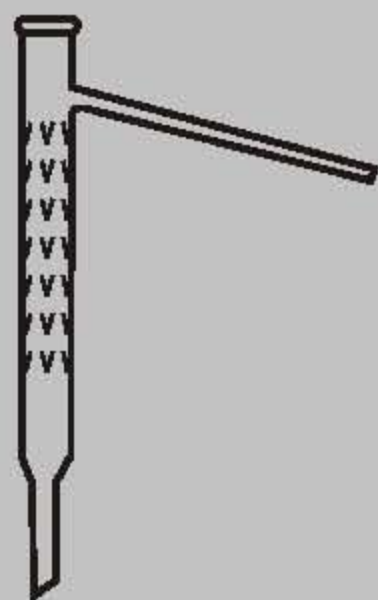

Lenght of Vigreux tube (mm)	O.D. of tube (mm)	O.D. Of side bulb (mm)	Lenght (mm)
250	21	6	410
400	23	7	560
500	25	8	690
600	27	9	790
800	30	10	1020
1000	33	11	1220

1211 REFRIGERENT DE AER

CONDENSER, AIR COOLING



For jacket lenght (mm)	O.D. of tube (mm)	Cooling area (dm ²)	Lenght (mm)
200	11	1.2	450
250	11	1.4	500
300	11	1.6	570
400	12	2.1	670
500	13	2.8	800
600	14	3.5	900

1213 REFRIGERENT LIEBIG

CONDENSER, LIEBIG, WITH FUSED INNEN TUBE



Lenght of jacket (mm)	O.D. of upper tube (mm)	Cooling area (dm ²)	Lenght (mm)
200	18	0.7	350
250	18	1.0	420
300	20	1.1	480
400	22	1.6	590
500	24	2.2	710
600	24	2.8	810
800	28	4.3	1050
1000	28	5.7	1250

0141 REFRIGERENT CU CIRCULAȚIE INTERNĂ ȘI EXTERNĂ DE APĂ

CONDENSER WITH INTERN AND EXTERN CIRCULATION OF WATER

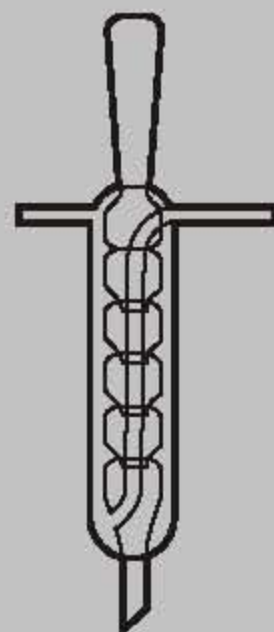

**Lenght
(mm)**

300
400
500

1214

REFRIGERENT CU BULE

CONDENSER, ALLIHN, WITH FUSED INNEN TUBE

Lenght of jacket (mm)	O.D. of upper tube (mm)	Cooling area (dm ²)	Lenght (mm)
200	18	1.0	350
250	18	1.5	420
300	20	1.8	480
400	22	2.7	590
500	24	3.7	710
600	24	4.9	800
800	28	7.6	1050
1000	28	10.0	1250
1200	33	12.7	1360
1500	33	17.0	1720

1215

REFRIGERENT CU SPIRALĂ

CONDENSER, GRAHAM, WITH COILED INNEN TUBE

Lenght of jacket (mm)	O.D. of upper tube (mm)	Cooling area (dm ²)	Lenght (mm)
200	18	2.3	350
250	20	2.7	420
300	20	3.3	480
400	22	4.7	590
500	24	7.7	710
600	24	8.2	810

1216

REFRIGERENT CU SPIRALĂ CU REFLUX

CONDENSER, REFLUX, DIMROTH, WITH COILED INNEN TUBE

Lenght of jacket (mm)	O.D. of upper tube (mm)	Cooling area (dm ²)	Lenght (mm)
300	20	5.4	480
400	22	7.3	590
500	24	9.2	710
600	24	10.5	810

1217

REFRIGERENT CU REFLUX

CONDENSER

Lenght of jacket (mm)	Cooling area (dm ²)	Lenght (mm)
300	2.4	420

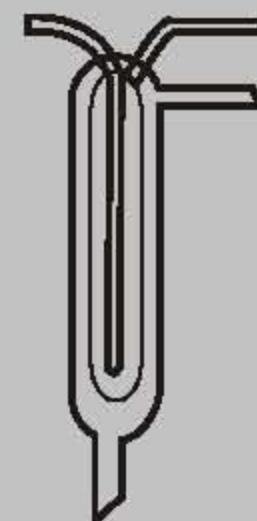



1221 ALONJĂ DREAPTĂ

ADAPTER TUBE

O.D. of tube (mm)	O.D. of bottom (mm)	Length (mm)
15	8	150
18	9	150
25	10	180
30	12	200

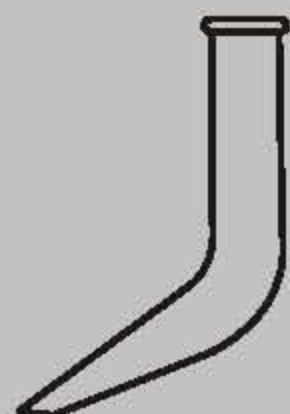

1222 ALONJĂ CURBĂ

ADAPTER TUBE

O.D. of tube (mm)	O.D. of bottom (mm)	Length (mm)
15	8	150
18	9	150
25	10	180
30	12	200

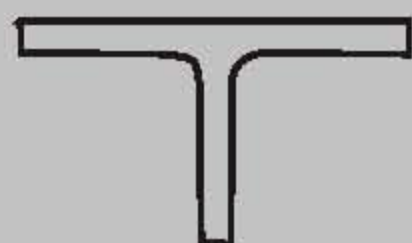

1224 TUB DE LERĂTURĂ FORMA: T

CONNECTION TUBE

O.D. of tube (mm)	Length branches (mm)	Length (mm)
7-8	50	100
10-11	60	120
15-16	75	150

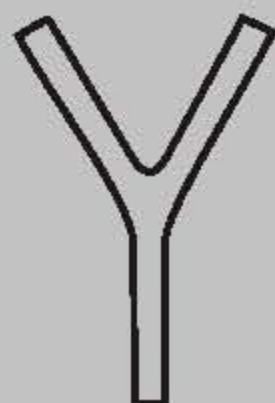

1225 TUB DE LERĂTURĂ FORMA: Y

CONNECTION TUBE

O.D. of tube (mm)	Length branches (mm)	Length (mm)
7-8	50	100
10-11	60	120
15-16	75	150



1226 TUB DE LERĂTURĂ FORMA: U

CONNECTION TUBE

O.D. of tube (mm)	Length branches (mm)	Length (mm)
7-8	50	100
10-11	60	120

1231

EPRUBETE NEGRADATE TIP. B VARIANTA A

TEST TUBES TYPE B, A VARIANT

O.D. of tube x lenght (mm)	O.D. of tube x Lenght (mm)
10 x 75	18 x 150
10 x 100	18 x 180
11 x 110	19 x 150
12 x 75	21 x 150
12 x 100	21 x 200
12 x 125	25 x 125
13 x 100	25 x 150
13 x 130	25 x 180
15 x 100	30 x 200
15 x 150	41 x 225

1236

EPRUBETE GRADATE

TEST TUBES GRADUATED

Capacitate Capacity (ml)	Valoare diviziunii Gradation divisions (ml)	O.D. of tube (mm)	Lenght (mm)
5	0.1	11	110
10	0.2	14	130
15	0.2	15	150
20	0.5	17	165
25	0.5	18	180
30	0.5	19	180
50	1.0	32	200

1237

EPRUBETE CU DOP RODAT

TEST TUBE, WITH GROUND, IN GLASS STOPPER

Capacity (ml)	Lenght (mm)
5	130
10	160
15	180
20	190

1238

EPRUBETE GRADATE CU DOP RODAT

TEST TUBE, WITH GRADUATION AND GROUND IN GLASS STOP

Capacity (ml)	Graduation (ml)	O.D. of tube (mm)	Lenght (mm)
5	0.1	12	130
10	0.2	15	160
15	0.2	16	180
20	0.5	18	190

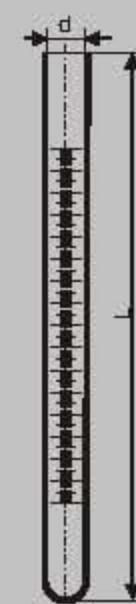

0011 EPRUBETE NEGRADATE TIP. B VARIANTA A

TEST TUBES TYPE B, A VARIANT

O.D. of tube (mm)	Length (mm)
8±0.5	80±1
10±1	100±2
12±1	120±2
14±1	140±2
16±1.2	160±3
18±1.2	180±3
20±2	200±3
25±2	160±3
40±2	130±2

1241 TUB CONIC PENTRU CENTRIFUGĂ

CENTRIFUGE TUBE, CONICAL

Capacity (ml)	O.D. Of tube (ml)	Length (mm)
5	14	90
10	17	110
15	19	120
25	23	140
50	33	150

1242 TUB CONIC GRADATĂ PENTRU CENTRIFUGĂ

CENTRIFUGE TUBE, CONICAL, WITH GRADUATION

Capacity (ml)	Graduation (ml)	O.D. Of tube (mm)	Length (mm)
5	0.1	13	95
10	0.1	17	110
15	0.1	19	120
25	0.2	23	140
50	0.2	33	150

0030 FIOLE GRADATE PENTRU CENTRIFUGĂ FORMA A

CENTRIFUGE TUBE FORM A

Capacity
(ml)

100

1243 TUB DE CENTRIFUGĂ

CENTRIFUGE TUBE

Capacity (ml)	O.D. Of tube (ml)	Length (mm)
50	35	100
100	41	115

1244

TUB DE CENTRIFUGĂ GRADATĂ

CENTRIFUGE TUBE WITH GRADUATIONS

Capacity (ml)	Graduation (ml)	O.D. Of tube (mm)	Lenght (mm)
50	1	35	100
100	2	41	115



1271A

ROBINET CU O CALE DREAPTĂ

STOPCOCK, STRAIGHT BORE TWO WAY

Bore of core (mm)	O.D. of side arm (mm)	Lenght of side arm (mm)
2	8	120
4	8	120
6	10	120
8	12	120
10	14	120
12	17	120
15	20	120
20	23	120



1272

ROBINET CU TREI CĂI ÎN T

STOPCOCK, STRAIGHT BORE THREE WAY

Bore of core (mm)	O.D. of side arm (mm)	Lenght of side arm (mm)
2	8	120
4	8	120
6	10	120
8	12	120
10	14	120

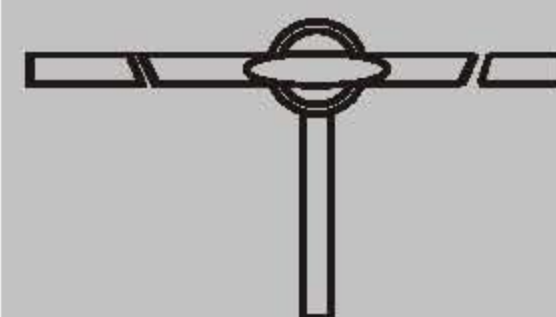

1271B

ROBINET CU O CALE DREAPTĂ CAPILAR

STOPCOCK, STRAIGHT BORE TWO WAY, CAPILLARY

Bore of core (mm)	O.D. of side arm (mm)	Lenght of side arm (mm)
2	8	120

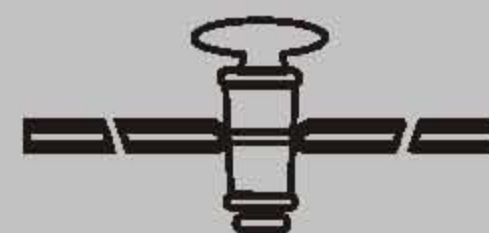

1273

ROBINET CU O CALE OBLICĂ

STOPCOCK, OBLIQUE BORE TWO WAY

Bore of core (mm)	O.D. of side arm (mm)	Lenght of side arm (mm)
2	8	120
4	8	120





1274 ROBINET CU TREI CĂI

STOPCOCK, OBLIQUE BORE THREE WAY

Bore of core (mm)	O.D. of side arm (mm)	Length of side arm (mm)
2	8	120
4	8	120

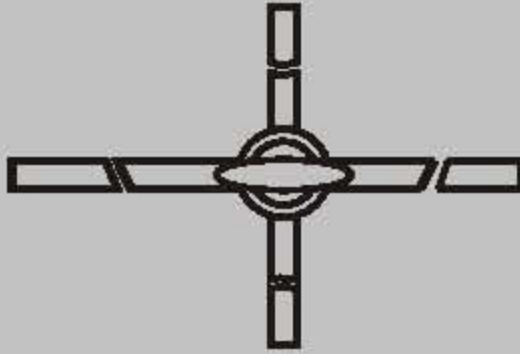

1275 ROBINET CU PATRU CĂI

STOPCOCK, OBLIQUE BORE FOUR WAY

Bore of core (mm)	O.D. of side arm (mm)	Length of side arm (mm)
2	8	120
4	8	120

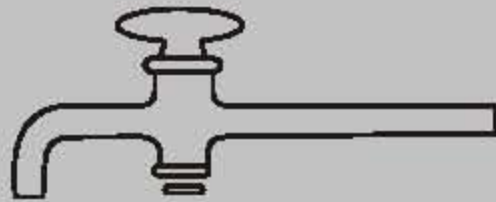

1276 ROBINET CU O CALE

STOPCOCK, TWO WAY

Bore of core (mm)	O.D. of side arm (mm)	Length of side arm (mm)
2	8	120
4	8	120

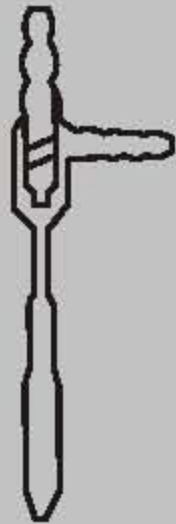

1281 TROMPĂ PENTRU APĂ (TROMPĂ DE VID)

WATER JET PUMP

O.D. Of upper tube (mm)	O.D. Of side tube (mm)	Length (mm)
18	9	330



1294 BAGHETĂ

STIRRER ROD

O.D. of rod (mm)	Length (mm)
6-8	250-330

1301 FIOLE DE CÂNTĂRIRE FORMA ÎNALTĂ

WEIGHING BOTTLES , HIGH FORM

O. D. (mm)	Height (mm)
25	25
25	40
30	50
30	60
35	70
40	70

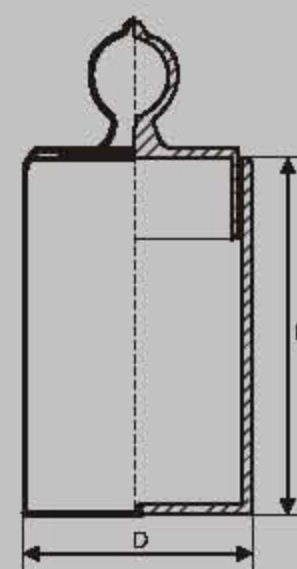

1302 FORMA JOASĂ

WEIGHING BOTTLES , LOW FORM

O. D. (mm)	Height (mm)
40	25
50	30
60	30
70	35

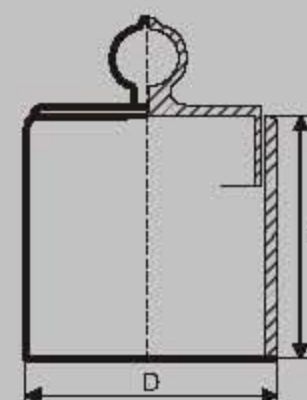

1314 SPĂLĂTOR DE GAZE, DRECHSEL

GAS WASHING BOTTLE DRECHSEL

Capacity (ml)	Height of body (mm)	Ground mouth	Total height (mm)
250	170	34/35	250
500	240	34/35	315

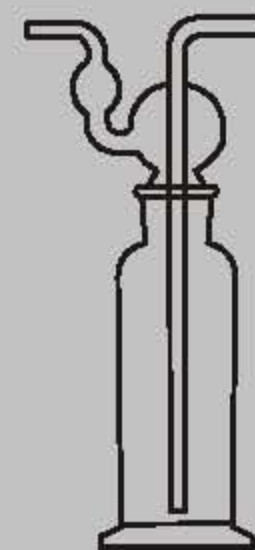

1324 TUB DE USCARE

DRYING TUBE

O.D.of tube (mm)	Length (mm)
13	100
15	150
20	200

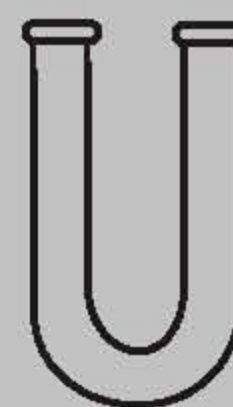

1325 TUB DE USCARE

DRYING TUBE

O.D.of tube (mm)	O.D.side tube (mm)	Height (mm)
13	5	100
15	6	150
20	7	200

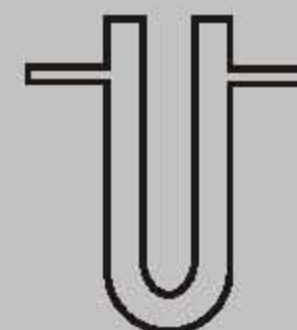

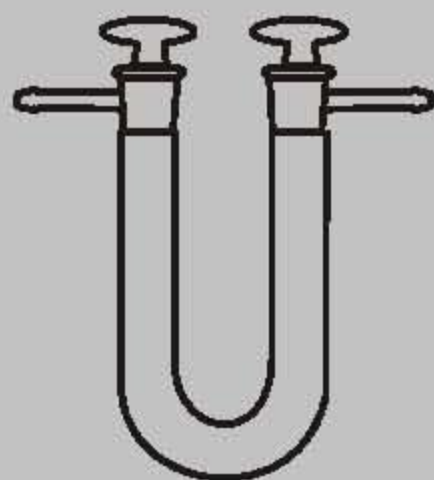

1326 TUB DE USCARE

DRYING TUBE

O.D.of tube (mm)	O.D.side tube (mm)	Height (mm)
13	5	100
15	6	150
20	7	200

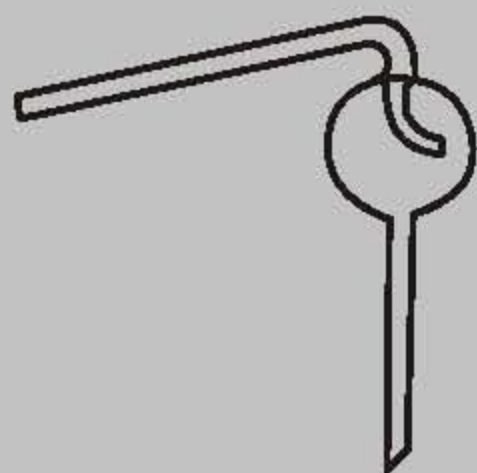

1341 VENTIL KJELDHAL

NITROGEN BULB

O.D.of tube (mm)	O.D. of side tube (mm)	Lenght (mm)
65	10	220

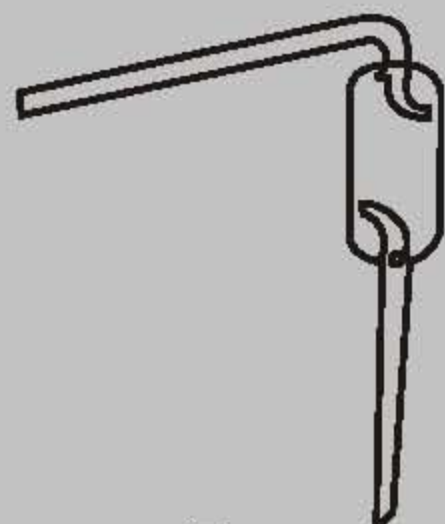

1342 VENTIL KJELDHAL

NITROGEN BULB

O.D.of tube (mm)	O.D. of side tube (mm)	Lenght (mm)
45	10	260

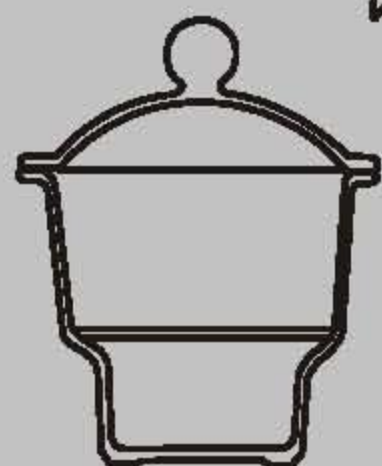

1351 EXICATOARE CU PLACĂ PORȚELAN

DESICCATOR, WITH PORCELAIN PLATE

I.D. (mm)	Height of plate (mm)	Total height (mm)
100	60	165
150	90	220
180	100	280
210	110	320
240	120	360
300	140	450

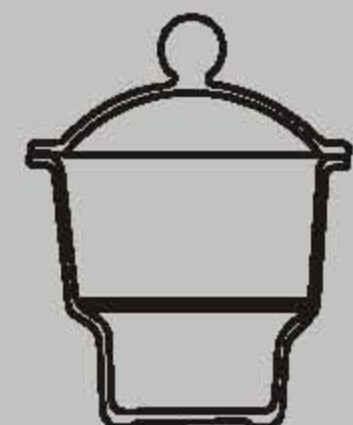

1352 EXICATOARE BRUNE CU PLACĂ PORȚELAN

DESICCATOR, AMBER, WITH POCELAIN PLATE

I.D. (mm)	Height of plate (mm)	Total height (mm)
100	60	165
150	90	220
180	100	280
210	110	320
240	120	360
300	140	450

1354 EXICATOARE PENTRU VID CU PLACĂ PORȚELAN

VACUUM DESICCATOR WITH PORCELAIN PLATE

I.D. (mm)	Height of plate (mm)	Total height (mm)
150	90	220
180	100	280
210	110	320
240	120	360
300	140	450

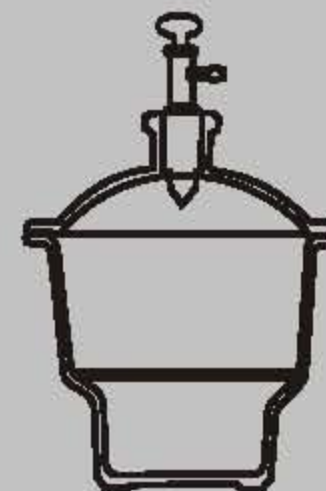

1355 EXICATOARE PENTRU VID CU PLACĂ PORȚELAN

VACUUM DESICCATOR, AMBER WITH PORCELAIN PLATE

I.D. (mm)	Height of plate (mm)	Total height (mm)
150	90	220
180	100	280
210	110	320
240	120	360
300	140	450

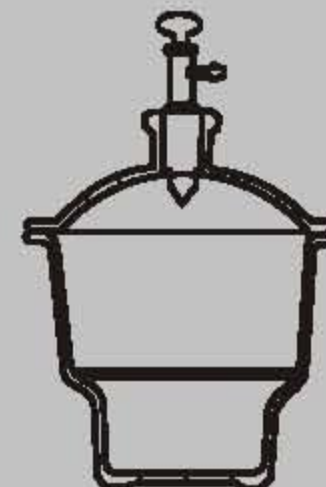

1361 APARAT KIPP

GAS GENERATOR, KIPP'S

Capacity (ml)	O.D. of bulb (mm)	Height (mm)
250	82	314
500	98	360
1000	130	450
2000	160	580

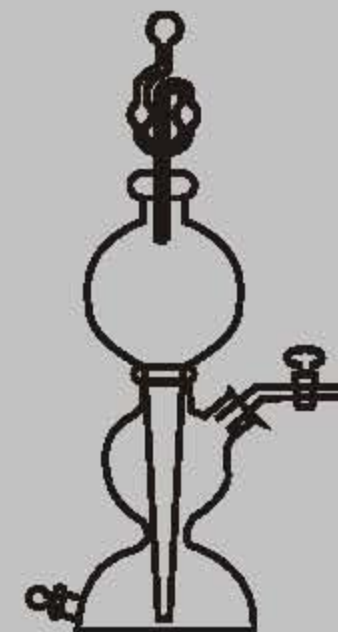

1371 CLOPOT STICLĂ

BELL JAR, CLEAR, WITH KNOB TOP

I.D. (mm)	Height (mm)
120	180
150	200
150	250
180	250
200	300

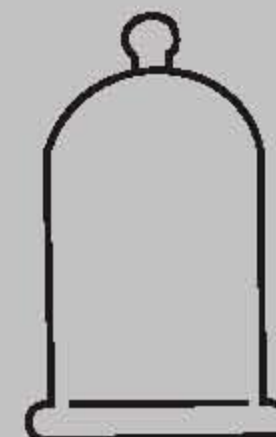

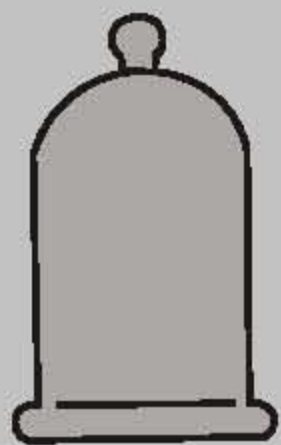

1372 CLOPOT STICLĂ BRUNĂ

BELL JAR AMBER, WITH KNOB TOP

I.D. (mm)	Height (mm)
120	180
150	200
150	250
180	250
200	300

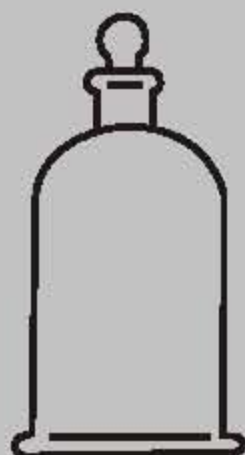

1373 CLOPOT STICLĂ CU DOP RODAT

BELL JAR WITH GROUND IN STOPPER

I.D. (mm)	Height (mm)
120	180
150	200
150	250
180	250
200	300

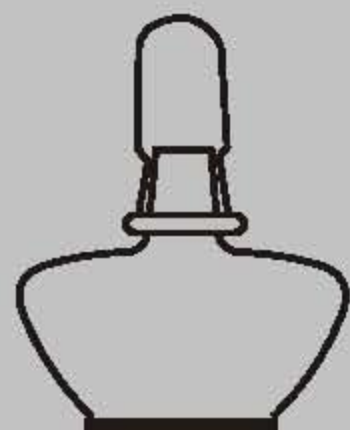

1381 SPIRTIERĂ

ALCOHOL LAMP

Capacity (ml)	Height (mm)
150	118
250	130



1383 MOJAR STICLĂ CU PISTIL

MORATAR WITH WITH GLASS PESTLE

I.D. (mm)	Height (mm)
60	40
75	40
90	50
120	60
150	85
180	96

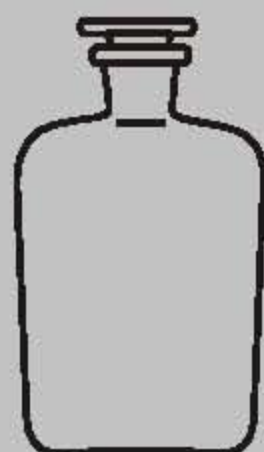

1401 STICLĂ ALBĂ CU DOP RODAT

REAGENT BOTTLE, CLEAR, NARROW MOUTH

Capacity (ml)	Dia of bottle (mm)	Dia of mouth (mm)	Height (mm)
30	40	18	76
60	46	22	85
125	57	24	110
250	70	27	135
500	85	33	172
1000	106	38	202
2500	145	48	270
5000	185	58	338
10000	225	68	430
20000	265	82	520

1402 STICLĂ BRUNĂ CU DOP RODAT

REAGENT BOTTLE AMBER, NARROW MOUTH

Capacity (ml)	Dia of bottle (mm)	Dia of mouth (mm)	Height (mm)
30	40	18	76
60	46	22	85
125	57	24	110
250	70	27	135
500	85	33	172
1000	106	38	202
2500	145	48	270
5000	185	58	338
10000	225	68	430

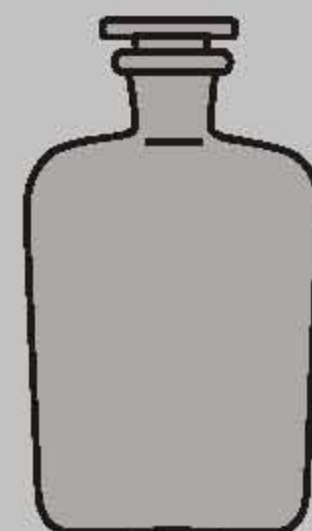

1403 BORCAN ALB CU DOP RODAT

REAGENT BOTTLE CLEAR, WIDE MOUTH

Capacity (ml)	Dia of bottle (mm)	Dia of mouth (mm)	Height (mm)
30	40	25	72
60	46	30	80
125	57	38	108
250	70	50	130
500	85	58	165
1000	106	65	188
2500	145	90	260
5000	185	110	330

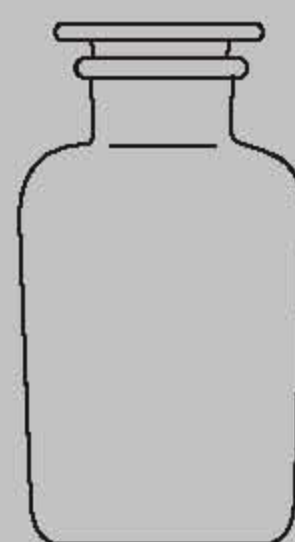

1404 BORCAN BRUNĂ CU DOP RODAT

REAGENT BOTTLE AMBER, WIDE MOUTH

Capacity (ml)	Dia of bottle (mm)	Dia of mouth (mm)	Height (mm)
30	40	25	72
60	46	30	80
125	57	38	108
250	70	50	130
500	85	58	165
1000	106	65	188
2500	145	90	260
5000	185	110	330

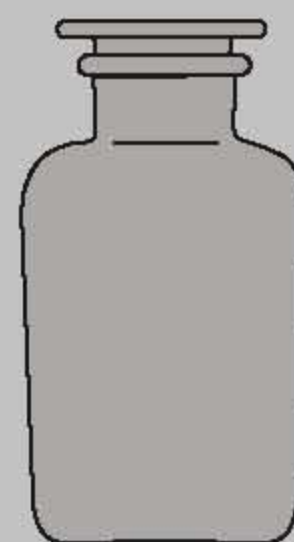

1421 VAS PENTRU APĂ DISTILLATĂ CU TUB LATERAL

ASPIRATOR BOTTLE

Capacity (ml)	Dia of neck (mm)	O.D. of lower mouth (mm)	Height (mm)
2500	48	30	270
5000	58	32	345
10000	68	35	420
20000	82	38	500

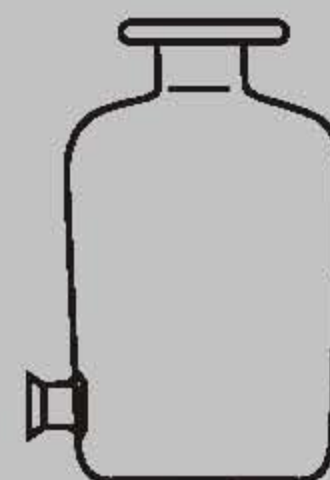

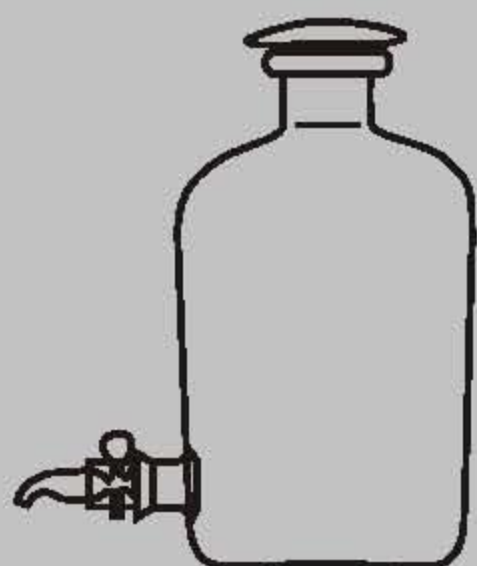

1422 VAS PENTRU APĂ DISTILLATĂ CU DOP RODAT ȘI ROBINET

ASPIRATOR BOTTLE

Capacity (ml)	Dia of neck (mm)	O.D. of lower mouth (mm)	Height (mm)
2500	48	30	270
5000	58	32	345
10000	68	35	420
20000	82	38	500

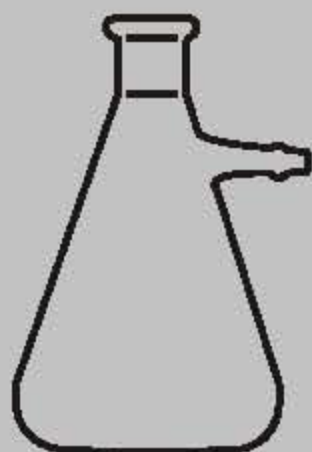

1432 VASE CONICE PENTRU FILTRARE

FILTER FLASK

Capacity (ml)	O.D. of side tube (mm)	Height (mm)
125	9	120
250	9	160
500	9	210
1000	9	245
2500	11	290
5000	11	370
10000	13	450



1451 STICLĂ ALBĂ CU PICURĂTOR

DROPPER BOTTLE

Capacity (ml)	O.D. of bottle (mm)	Height (mm)
30	40	76
60	46	85
125	57	110



1452 STICLĂ BRUNĂ CU PICURĂTOR

DROPPER BOTTLE AMBER

Capacity (ml)	O.D. of bottle (mm)	Height (mm)
30	40	76
60	46	85
125	57	110



1482 PISETĂ

WASHING BOTTLE CONICAL

Capacity (ml)	Ground mouth (mm)	Lenhgt (mm)
250	29 x 32	83
500	29 x 32	98
1000	29 x 32	128

0107 BUTIROMETRU SMÂNTÂNĂ METODA SHULTZ; METODA KOEHLER
 BUTIROMETER FOR CREAM

Procent

0-40%

0103 BUTIROMETRU LAPTE METODA GERBER
 BUTIROMETER FOR MILK

Procent

0-6%

0-7%

0-8%

0-10%

0398 PIPETE AUTOMATE KIPP
 KIPP - AUTOMAT

Capacitate ml

CodeCapacity

1

10

0091 PIPETE PENTRU SMÂNTÂNĂ 5 ML. CU DOUĂ BULE
 PIPETTE FOR CREAM 5 ML

Capacity
(ml)

5

1705 PIPETE PENTRU LAPTE 11 ML.
 PIPETTE FOR MILK 11 ML

Capacity
(ml)

11

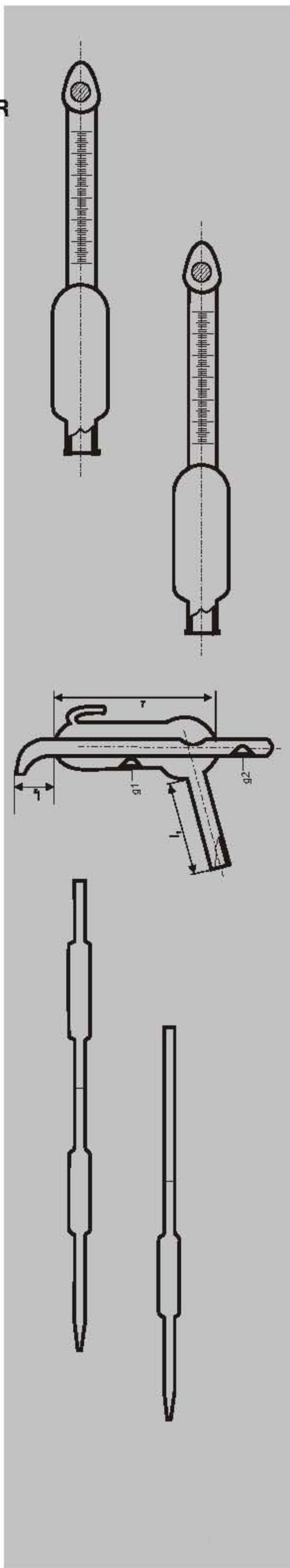

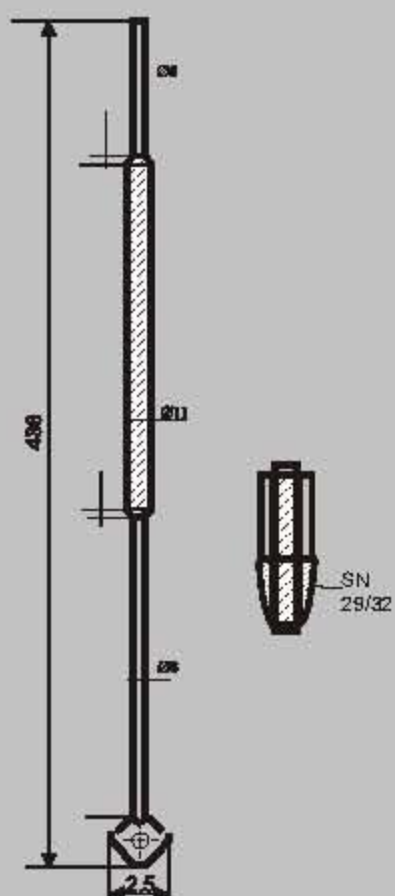

0401 APARAT KPG

K.P.G. APPARAT

0159 APARAT PENTRU SAPONIFICARE

BALLOON OF SOAP

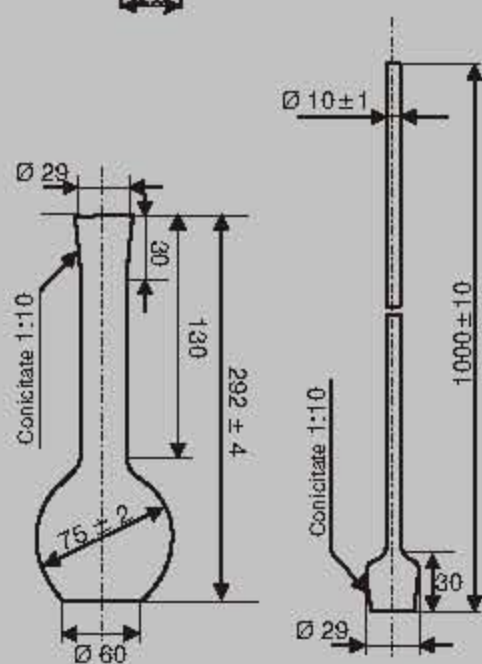

0425 BUTELII PENTRU BIBEROANE

BOTTLE, FEEDING

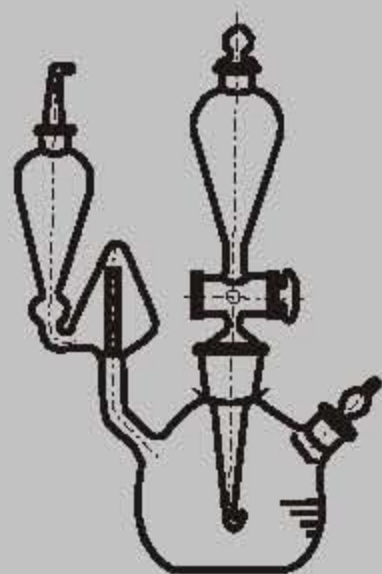

0116 APARAT GEISLER PENTRU DETERMINAREA CARBONAȚILOR

GEISLER APPARAT

0403 APARAT PARNAS - WAGNER

PARNAS - WAGNER APPARAT

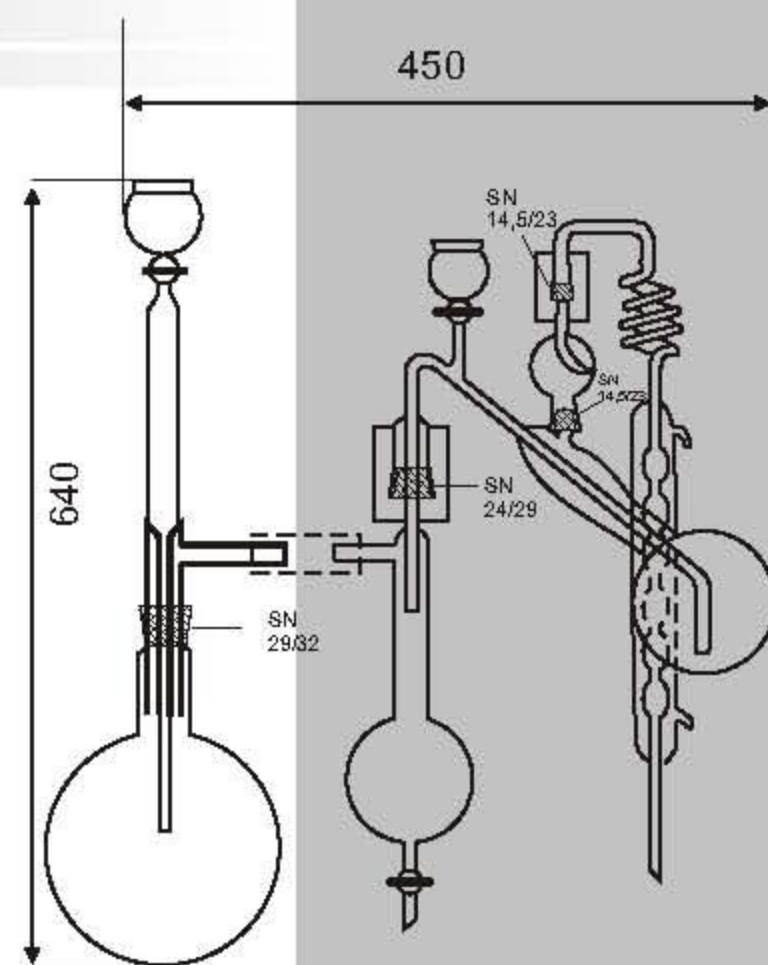

0158 APARAT PENTRU ACETILARE

BALLOON OF ACETILARE

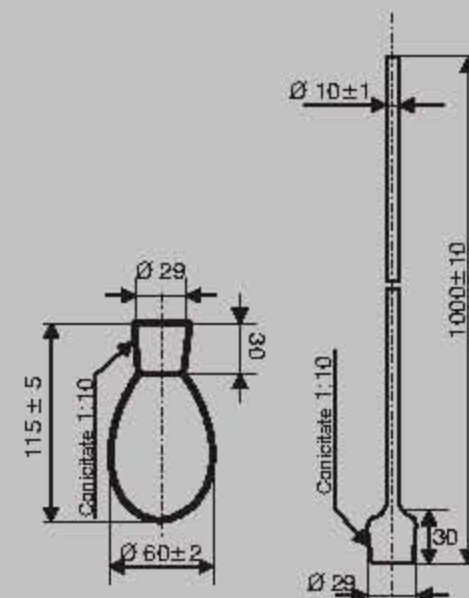

0164 APARAT DE DISTILAT APĂ

WATER DISTILLATOR

Capacitate balon fierbere
(ml)

2000

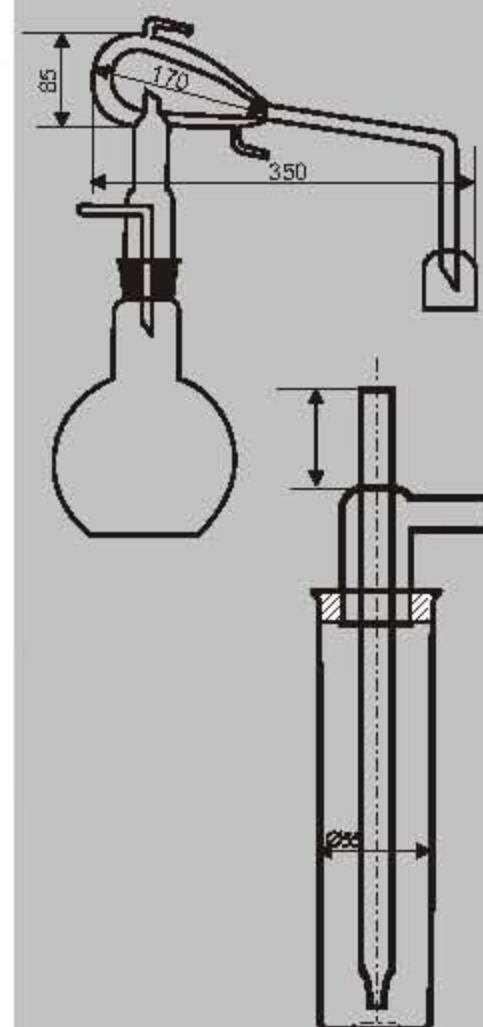

0398 VAS DE RECOLTAT PRIN IZBIRE

APPARATUS IMPINGER

0073 DIFERITE VIZOARE TERMOREZISTENTE

VIEWFINDERS

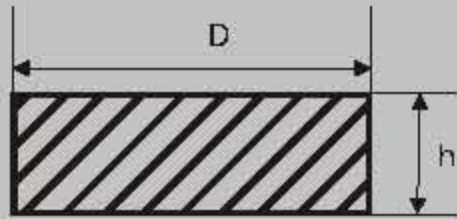

Dimensiuni, mm

Dimension, mm

D	h
15 - 300	8 - 60

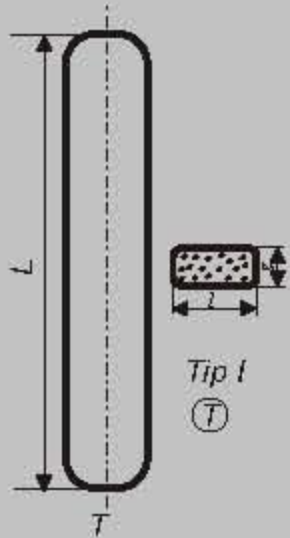

0423 STICLE PRISMATICE INDICATOARE DE NIVEL

LEVEL INDICATORS

Dimensiuni, mm

Dimension, mm

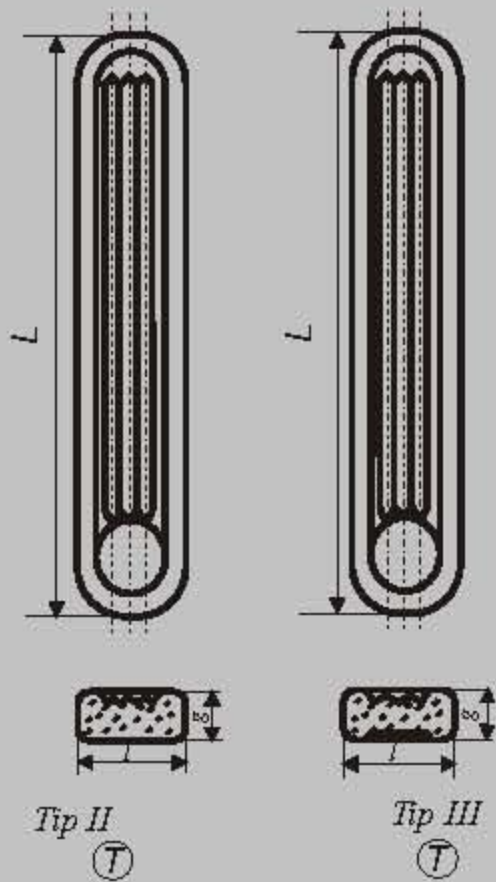

L	l	g
140	30	17
160	34	20
190		22
220		
250		
280		
320		
340		

0416 DIFERITE TUBURI DE ROTAMETRE

GRADUATED GLASS TUBES FOR FLOWMETERS



1503 PÂLNIE CU COADĂ LUNGĂ

FUNNEL 60 APROX, LONG STEM

Diameter (mm)	O.D. of stem (mm)	Length (mm)
50	7	150
60	8	150
75	9	150
90	11	150

1504 PÂLNIE CU COADĂ SCURTĂ

FUNNEL, SHORT STEM

Diameter (mm)	O.D. of stem (mm)	Length (mm)
40	7	50
50	7	50
60	8	60
75	9	75
90	11	90
120	12	120
150	15	150

1524 PÂLNIE DE SIGURANȚĂ

TUBES FOR FERMENTATION

O.D. of top (mm)	O.D. of stem (mm)
40	7-8

1531 PÂLNIE DE PICURARE

DROPPING FUNNEL, STOPPER AND STOPCOCK

Capacity (ml)	Dia of stem x length (mm)	Length (mm)
60	9 x 140	270
125	9 x 140	285
250	10 x 140	310
500	10 x 140	330

1543 PÂLNIE DE SEPARARE FORMA PARĂ

SEPARATORY FUNNEL, PEAR SHAPE, STOPPER AND STOPCOCK

Capacity (ml)	Dia of stem x length (mm)	Length (mm)
10	8 x 60	126
20	8 x 60	135
60	10 x 70	220
125	10 x 70	260
250	11 x 70	290
500	12 x 70	330
1000	12 x 70	400

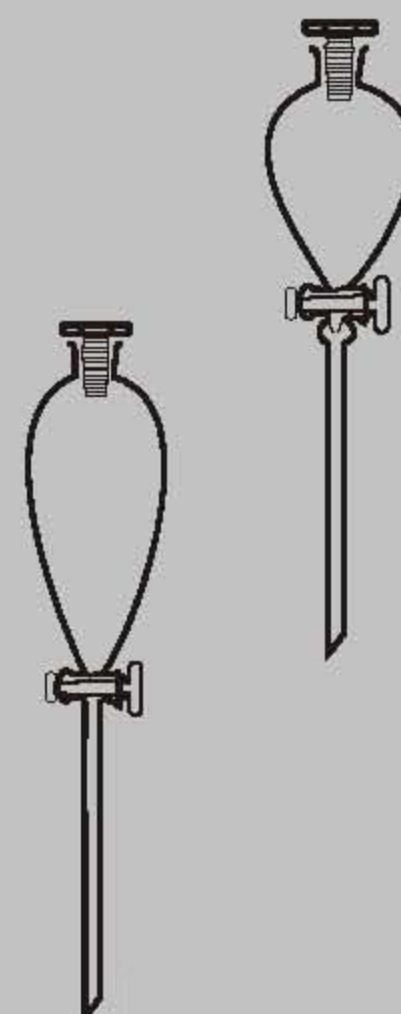
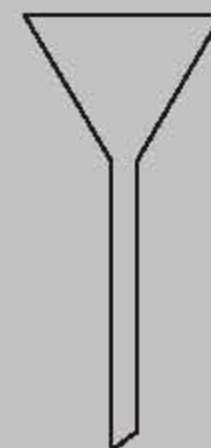



1544 PÂLNIE DE SEPARARE FORMA PARĂ GRADATĂ

SEPARATORY FUNNEL, PEAR SHAPE, WITH GRADUATIONS, STOPCOCK

Capacity (ml)	Graduation (ml)	Dia of stem x length (mm)	Length (mm)
60	5	10 x 70	220
125	5	10 x 70	260
250	10	11 x 70	290
500	20	12 x 70	330
1000	50	12 x 70	400



1545 PÂLNIE DE SEPARARE CILINDRICĂ

SEPARATORY FUNNEL, CYLINDER SHAPE, STOPPER, STOPCOCK

Capacity (ml)	Dia of stem x length (mm)	Length (mm)
60	9 x 80	220
125	9 x 80	260
250	10 x 110	290
500	10 x 110	330
1000	12 x 110	400



1546 PÂLNIE DE SEPARARE CILINDRICĂ GRADATĂ

SEPARATORY FUNNEL, CYLINDER SHAPE, WITH GRADUATION

Capacity (ml)	Dia of stem x length (mm)	Length (mm)
60	9 x 80	220
125	9 x 80	260
250	10 x 110	290
500	10 x 110	330
1000	12 x 110	400

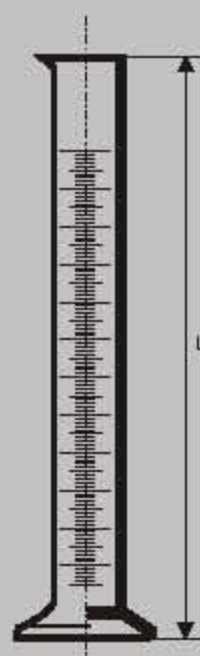

1601 CILINDRI GRADAȚI TIP. 1

GRADUATED CYLINDERS TYPE 1.

Capacity (ml)	Graduation (ml)	Capacity tolerance (\pm ml)	Height (mm)
5	0.1	0.1	110
10	0.2	0.2	135
25	0.5	0.5	160
50	1.0	0.5	195
100	1.0	1	250
250	2 or 5	2	300
500	5	5	350
1000	10	10	430
2000	20	20	500

1603 CILINDRI GRADAȚI CU DOP RODAT

MEASURING CYLINDER, WITH GRADUATIONS, STOPPER

Capacity (ml)	Graduation (ml)	Capacity tolerance (\pm ml)	Height (mm)
10	0.2	0.1	150
25	0.5	0.25	150
50	1.0	0.25	215
100	1.0	0.5	270
250	2 or 5	1.0	320
500	5	2.5	380
1000	10	5	460
2000	20	10	530

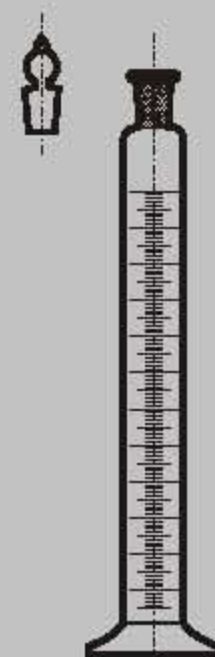

1621A BALOANE COTATE CU DOP RODAT (CU DOP PLASTIC)

FLASKS VOLUMETRIC WITH GLASS STOPPER OR PLASTIC STOPPER

Capacity (ml)	Capacity tolerance (\pm ml)	Ground mouth	Height (mm)
5	0.02	7/11	74
10	0.02	7/11	90
25	0.03	10/13	110
50	0.05	10/13	140
100	0.10	12/14	170
200	0.15	14/15	210
250	0.15	14/15	220
500	0.25	16/16	260
1000	0.4	19/17	310
2000	0.6	24/20	370

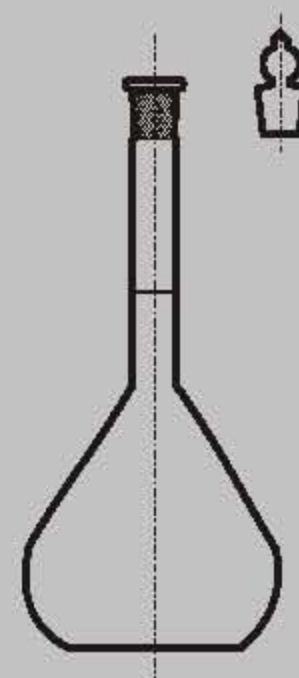

1622A BALOANE COTATE BRUNE CU DOP RODAT (CU DOP PLASTIC)

VOLUMETRIC FLASK AMBER WITH GLASS STOPPER OR PLASTIC STOPPER

Capacity (ml)	Capacity tolerance (\pm ml)	Ground mouth	Height (mm)
5	0.02	7/11	74
10	0.02	7/11	90
25	0.03	10/13	110
50	0.05	10/13	140
100	0.10	12/14	170
200	0.15	14/15	210
250	0.15	14/15	220
500	0.25	16/16	260
1000	0.4	19/17	310
2000	0.6	24/20	370

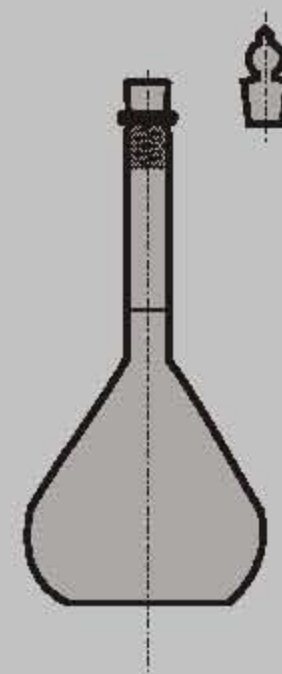

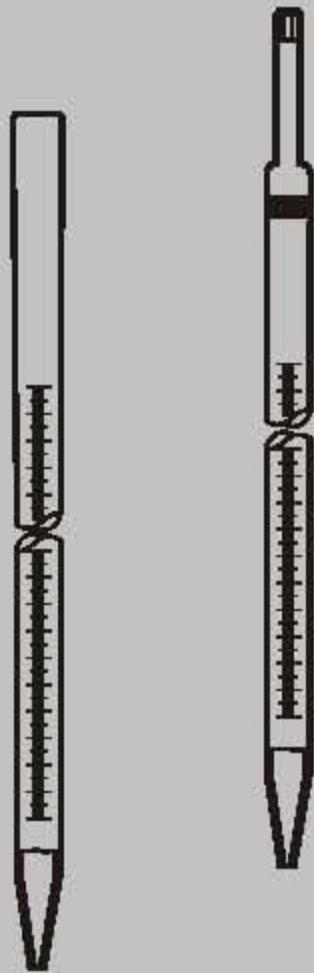

1630A PIPETĂ GRADATĂ

MEASURING PIPETTE, WITH CODING BAND.

Capacity (ml)	Graduation (ml)	Capacity tolerance (\pm ml)	Flow rate (s)	Length (mm)
1	0.01	0.008	4-10	350
2	0.02	0.012	4-12	350
5	0.05	0.025	6-14	350
10	0.10	0.05	7-17	350
25	0.10	0.01	11-21	470
50	0.20	0.01	15-25	480



1633A PIPETĂ CU BULĂ

VOLUMETRIC PIPETTE WITH ONE MARK

Capacity (ml)	Capacity tolerance (\pm ml)	Flow rate (s)	Length (mm)
1	0.007	7-12	330
2	0.010	7-12	340
3	0.015	15-25	360
5	0.015	15-25	400
10	0.02	20-30	450
15	0.025	20-30	520
20	0.03	25-35	560
25	0.03	25-35	570
50	0.05	30-40	600
100	0.08	35-45	640



1644A BIURETĂ FĂRĂ ROBINET CU LINIE SCHELLBACH

BURETTE WITH BLUE LINE, ON WHITE BACK

Capacity (ml)	Graduation (ml)	Capacity tolerance (\pm ml)	Length (mm)
10	0.05	0.025	600
25	0.1	0.05	630
50	0.1	0.05	860
100	0.2	0.10	860

0116A BIURETĂ CU ROBINET LATERAL CU LILNE SCHELLBACH

BURETTE WITH LATERAL STOPCOCK WITH BLUE LINE ON WHITE BACK

Capacity (ml)	Graduation (ml)	Capacity tolerance (\pm ml)	Lenght (mm)
10	0.05	0.025	600
25	0.1	0.05	630
50	0.1	0.05	860
100	0.2	0.10	860

1645A BIURETĂ CU ROBINET DREPT CU LINIE SCHELLBACH

BURETTE WITH BLUE LINE, ON WHITE BACK

Capacity (ml)	Graduation (ml)	Capacity tolerance (\pm ml)	Lenght (mm)
10	0.05	0.5	600
25	0.1	0.1	630
50	0.1	0.1	860
100	0.2	0.2	860

1657A BIURETĂ AUTOMATĂ PELLET CU LINIE SCHELLBACH

AUTOMATIC BURETTE PELLET ON WHITE BACK

Capacity (ml)	Graduation (ml)	Capacity of reservoir (ml)	Lenght (mm)
25	0.1	2000	830
50	0.1	2000	1080
100	0.2	2000	1080

1663A MICROBIURETĂ

MICROBURETTE WITH SIDE FILLING TUBE

Capacity (ml)	Graduation (ml)	Capacity tolerance (\pm ml)	Lenght (mm)
1	0.01	0.01	620
2	0.01	0.01	700
3	0.02	0.01	730
5	0.02	0.01	730
10	0.05	0.025	730

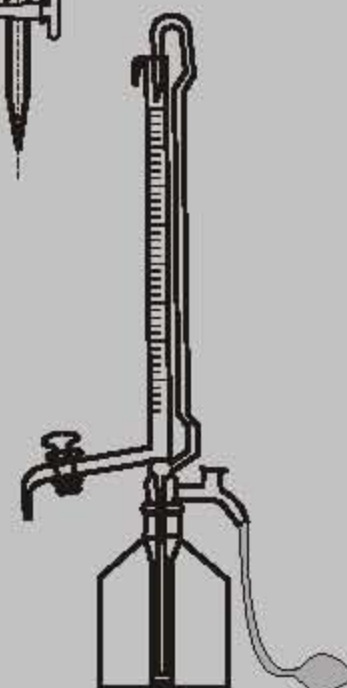
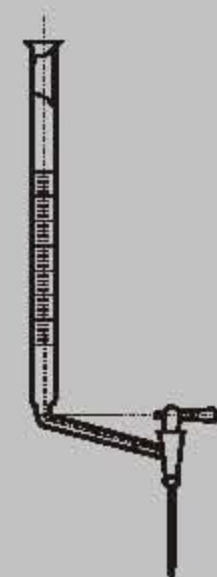



1677 DOZATOR AUTOMAT

AUTOMATIC FILLING APPARATUS

Capacity (ml)	Capacity tolerance (\pm ml)	Capacity of bottle (ml)
5	0.2	500
10	0.2	500
15	0.4	500
20	0.4	500
25	0.5	500

1689 TUB DE ABSORTIE

ABSORBER APPARATUS

O.D. of tube (mm)	O.D. Of side tube (mm)	Height (mm)
20	5.5	205

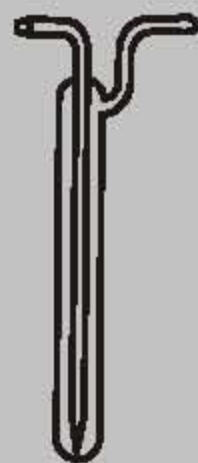

1781 APARAT DEAN-STARKE

WATER DETERMINATION APPARATUS

Art No.	Spare parts
5001/500/24	500 ml round boiling flask
1781-2	10 ml receiving tube
1781-3	400 mm straight condenser

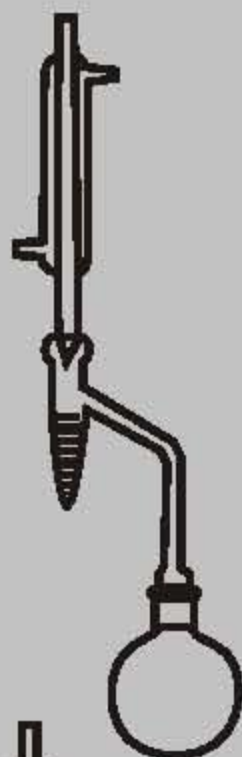

1788 APARAT PT DETERMINAREA ULEIURILOR VOLATILE

VOLATILE OIL DETERMINATION APPARATUS

Art No.	Spare parts
1788-1	500 ml volatile oil determination tube
1788-2	4 mm global condenser
5001/500/34	500 ml round boiling flask
5001/1L/34	1000 ml round boiling flask
5001/1L/34	2000 ml round boiling flask



0160**APARAT DE EXTRACȚIE SOXHLET**

SOXHLET EXTRACTOR APPARAT

Capacity of extractor (ml)	Capacity of flask (ml)
100	250
250	500
500	1000
1000	2000
2000	2000

1801**APARAT DE DISTILLARE**

DISTILLING APPARATUS

Capacity of flask (ml)	Length of condenser (mm)	Ground mouth	Height (mm)
500	200	24/29	200
1000	250	24/29	280
2000	300	29/32	350

1802**APARAT DE DISTILLARE**

DISTILLING APPARATUS

Capacity of flask (ml)	Length of Jacket (mm)
500	200

1803**APARAT DE DISTILLARE**

DISTILLING APPARATUS

Capacity of flask (ml)	Length of Jacket (mm)
5000	600

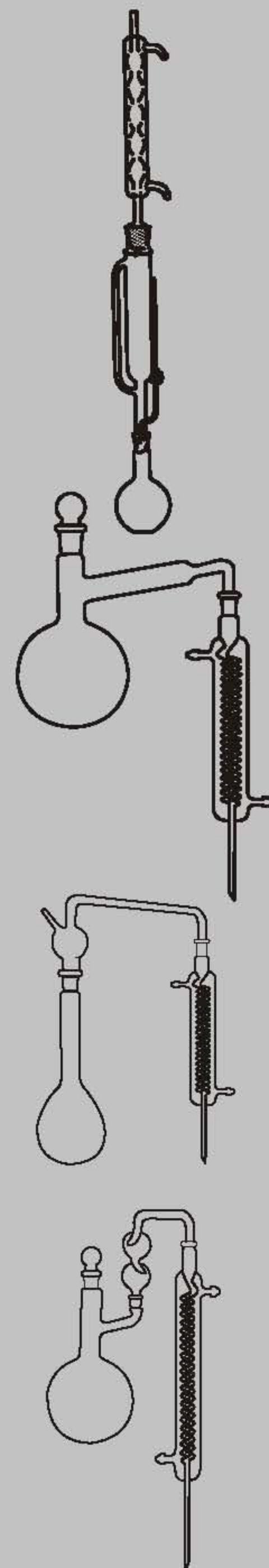

1861 PICNOMETRU GAY LUSSAC

SPECIFIC GRAVITY BOTTLE



Capacity (ml)	Diameter of mouth (mm)	Height (mm)
5	7	60
10	7	70
25	10	85
50	10	100
100	10	110

0422 PICNOMETRU CU TERMOMETRU

BOTTLES, SPECIFIC GRAVITY WITH THERMOMETER



Capacity (ml)

5
10
25
50
100

1871 TUB COLORIMETRIC NESSLER

COLORIMETER TUBE

Capacity (ml)	Graduation (ml)	Tolerance (\pm ml)	Height (mm)
10	5,10	0.1	130
25	20,25	0.25	150
50	25,50	0.4	180
100	50,100	0.6	210

1872 TUB COLORIMETRIC NESSLER CU DOP RODAT

COLORIMETER TUBE WITH GLASS STOPPER

Capacity (ml)	Graduation (ml)	Tolerance (\pm ml)	Height (mm)
10	5,10	0.1	140
25	20,25	0.25	170
50	25,50	0.4	200
100	50,100	0.6	240



1915 PIPETĂ HEMPEL

GAS PIPETTE

O.D. (mm)	O.D. of neck (mm)	O.D. of bulb (mm)	Height (mm)
60	26	66	300
73	26	66	300

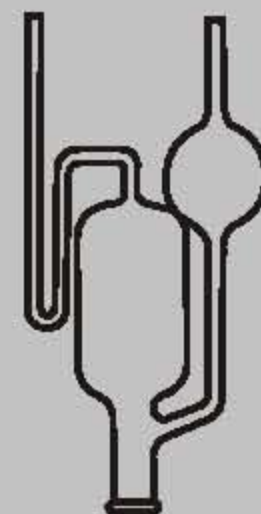

1941 BIURETĂ HEMPEL

GAS MEASURING BURETTE

Capacity (ml)	Graduation (ml)			Length (mm)
	0-5	25-55	65-100	
100	0.2	1	0.2	580



1942 BIURETĂ PENTRU APARAT ORSAT

OXIGEN MEASURING BURETTE

Capacity (ml)	Graduation (ml)			Length (mm)
	0-10	10-94	94-100	
100	0.5	5	0.1	480

1901 APARAT ORSAT

ORSAT APPARAT

Art No.	Spare parts
1901-1	3 pcs gas absorption pipette
1901-2	100 ml measuring burette with jacket
1901-3	manifold tube with four glass stopcocks
1901-4	250 ml levelling bulb
1901-5	U- shape drying tube
1901-6	straight drying tube
1901-7	3 pcs bent adapter

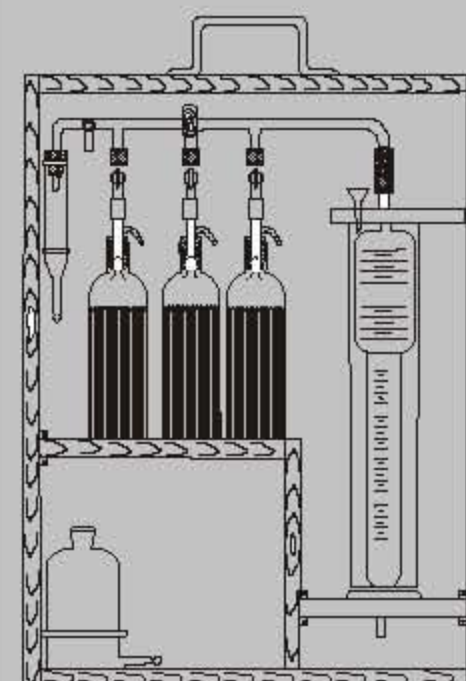

5001 BALON CU FUND ROTUND CU ŞLIF

BOILING FLASK ROUND BOTTOM, SHORT NECK

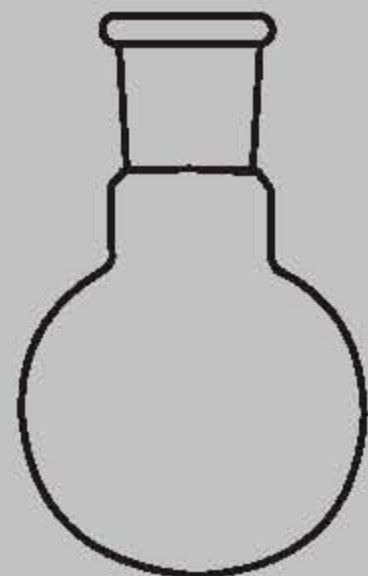

Capacity (ml)	Ground mouth	O.D. Of bulb (mm)	Height (mm)
5	10/19	27	56
5	14/23	27	60
10	10/19	33	66
10	14/23	33	68
25	10/19	41	70
25	14/23	41	75
25	19/26	41	79
50	14/23	53	88
50	19/26	53	94
50	24/29	53	97
50	29/32	53	105
100	14/23	65	100
100	19/26	65	106
100	24/29	65	109
100	29/32	65	117
150	19/26	76	117
150	24/29	76	120
250	19/26	88	134
250	24/29	88	139
250	29/32	88	145
500	19/26	110	158
500	24/29	110	161
500	29/32	110	167
500	34/35	110	170
1000	19/26	140	188
1000	24/29	140	196
1000	29/32	140	199
1000	34/35	140	202
2000	24/29	175	231
2000	29/32	175	234
2000	34/35	175	237
3000	29/32	199	281
3000	34/35	199	284
3000	40/38	199	287
5000	40/38	135	333
5000	50/42	135	337
10000	50/42	297	410
10000	60/46	297	414

5002 BALON CU FUND ROTUND CU ŞLIF

BOILING FLASK ROUND BOTTOM, LONG NECK STANDARD GROUND MOUTH

Capacity (ml)	Ground mouth	O.D. of bulb (mm)	Height (mm)
50	14/23	53	130
50	19/26	53	130
50	24/29	53	130
100	19/26	65	145
100	24/29	65	145
250	24/29	88	165
250	29/32	88	165
500	24/29	110	210
500	29/32	110	210
1000	24/29	140	250
1000	29/32	140	250
2000	24/29	175	310
2000	29/32	175	310
3000	34/35	199	360
3000	40/38	199	360
5000	45/40	235	380
5000	50/42	235	380
10000	50/42	297	550
10000	60/46	297	550

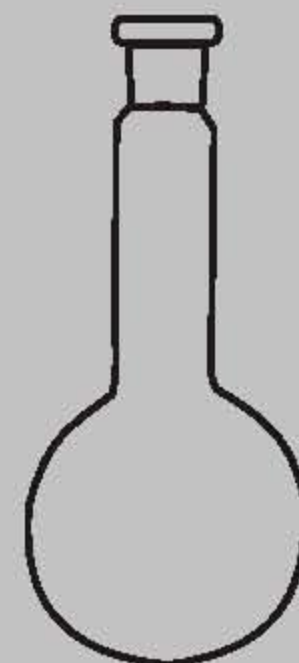

5003 BALON CU FUND ROTUND CU 2 GÂTURI CU ŞLIF

FLASK OBLIQUE SHAPE, WITH TWO NECKS STANDARD GROUND MOUTH

Capacity (ml)	Midle ground mouth	Side ground mouth	Height (mm)
100	19/26	14/23	106
100	24/29	14/23	109
250	19/26	14/23	134
250	24/29	14/23	139
250	24/29	19/26	139
250	29/32	14/23	145
250	29/32	19/26	145
500	19/26	14/23	158
500	24/29	14/23	161
500	24/29	19/26	161
500	29/32	14/23	167
500	29/32	19/26	167
1000	24/29	14/23	196
1000	24/29	19/26	196
1000	24/29	24/29	196
1000	29/32	14/23	200
1000	29/32	19/26	200
1000	29/32	24/29	200
2000	24/29	19/26	231
2000	24/29	24/29	231
2000	29/32	19/26	234
2000	29/32	24/29	234

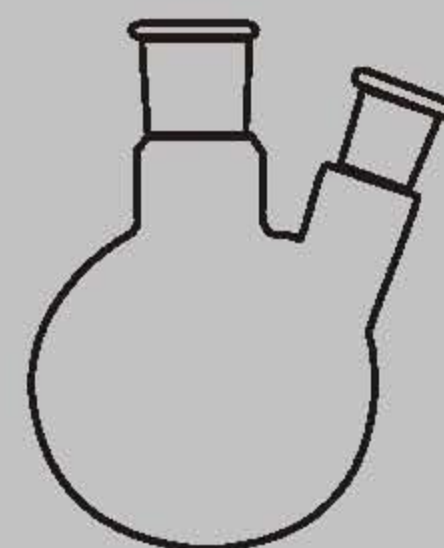

5004 BALON CU FUND ROTUND CU 3 GÂTURI CU ȘLIF

FLASK OBLIQUE SHAPE, WITH 3 NECKS STANDARD GROUND MOUTH

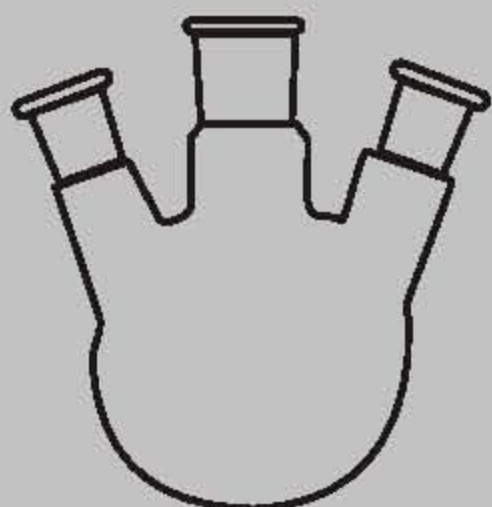

Capacity (ml)	Midle ground mouth	Side ground mouth	Height (mm)
100	19/26	14/23	106
250	19/26	14/23	134
250	19/26	19/26	134
250	24/29	14/23	139
250	24/29	19/26	139
250	24/29	24/29	139
250	29/32	14/23	145
250	29/32	19/26	145
500	19/26	14/23	158
500	19/26	19/26	158
500	24/29	14/23	161
500	24/29	19/26	161
500	24/29	24/29	161
500	29/32	14/23	167
500	29/32	19/26	167
1000	19/29	14/23	188
1000	19/29	19/26	180
1000	24/29	24/23	196
1000	24/29	19/26	196
1000	24/29	24/29	196
1000	29/32	14/23	200
1000	29/32	19/26	200
1000	29/32	24/29	200
1000	29/32	29/32	200
2000	24/29	24/29	231
2000	29/32	19/26	234
2000	29/32	24/29	234
2000	29/32	29/32	234
3000	29/32	24/29	281
3000	34/35	24/29	284
5000	40/38	24/29	333
5000	50/42	24/29	337

5006 BALON CU FUND ROTUND CU 4 GÂTURI CU ŞLIF

FLASK OBLIQUE SHAPE, WITH 4 NECKS STANDARD GROUND MOUTH

Capacity (ml)	Midle ground mouth	Side ground mouth	Straight ground mouth	Height (mm)
500	24/29	19/26	14/23	161
500	24/29	19/26	19/26	161
500	24/29	24/29 or 19/26	14/26	161
500	29/32	24/29 or 19/26	14/26	167
500	29/32	24/29	14/26	167
1000	24/29	19/26	14/23	196
1000	24/29	19/26	19/26	196
2000	24/29	19/26	19/26	231
2000	29/32	24/29 or 19/26	14/23	234
3000	29/32	24/29	14/23	281
3000	34/35	24/29	14/23	284
3000	34/35	24/29 or 19/26	19/26	284
5000	40/38	24/29 or 19/26	14/23	333

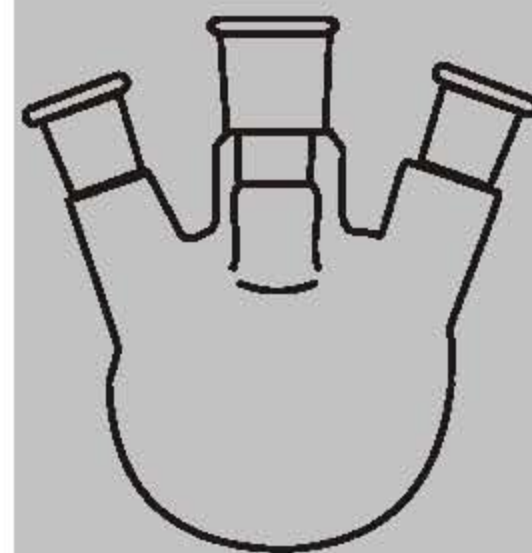

5007 BALON CU FUND PLAT CU ŞLIF, FORMA JOASĂ

BOILING FLASK FLAT BOTTOM, SHORT NECK STANDARD GROUND MOUTH

Capacity (ml)	Ground mouth	O.D. of bulb (mm)	Height (mm)
25	14/23	41	70
50	14/23	53	88
50	19/26	53	94
100	14/23	65	100
100	19/26	65	106
100	24/29	65	109
150	19/26	76	117
150	24/29	76	120
250	19/26	88	134
250	24/29	88	139
500	19/26	110	158
500	24/29	110	161
500	29/32	110	167
1000	24/29	140	196
1000	29/32	140	199
2000	29/32	175	234
2000	34/35	175	237
5000	34/35	235	320

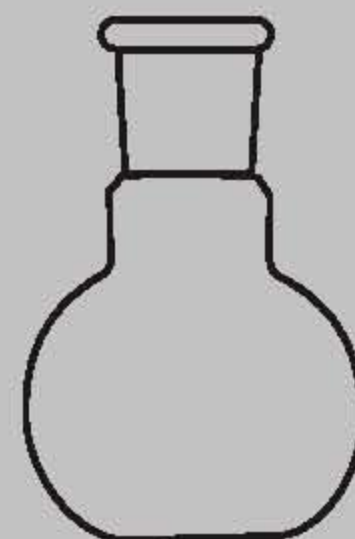

5008 BALON CU FUND PLAT CU ŞLIF, FORMA ÎNALTĂ

BOILING FLASK FLAT BOTTOM, LONG NECK STANDARD GROUND MOUTH

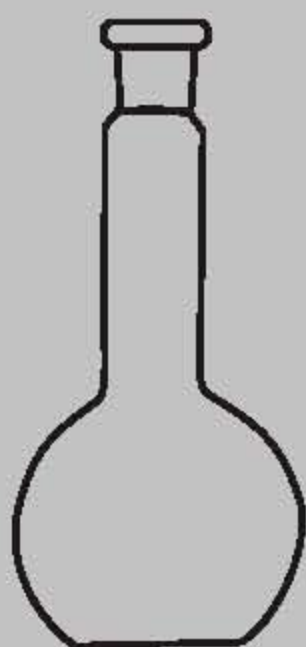

Capacity (ml)	Ground mouth	O.D. of bulb (mm)	Height (mm)
50	19/26	53	120
100	19/26	65	140
250	19/26	88	160
250	24/29	88	160
500	24/29	110	200
500	29/32	110	200
1000	24/29	140	250
1000	29/32	140	250
2000	29/32	175	300

5011 BALON ROTAVAPOR CU ŞLIF

FLASK EGGPLANT SHAPE STANDARD GROUND MOUTH



Capacity (ml)	Ground mouth	O.D. of bulb (mm)	Height (mm)
5	10/19	26	50
10	10/19	30	70
10	14/23	30	70
25	10/19	39	80
25	14/23	39	80
25	19/26	39	80
50	14/23	51	100
50	19/26	51	100
50	24/29	51	100
50	29/32	51	100
100	14/23	60	110
100	19/26	60	110
100	24/29	60	110
100	29/32	60	110
250	19/26	81	140
250	24/29	81	140
250	29/32	81	140
500	24/29	101	170
500	29/32	101	170
1000	24/19	125	210
1000	29/32	125	210

5012 BALON KJELDHAL CU ŞLIF

NITROGEN FLASK LONG NECK STANDARD GROUND MOUTH

Capacity (ml)	Ground mouth	O.D. of bulb (mm)	Height (mm)
25	14/23	40	140
50	14/23	52	190
50	19/26	52	190
100	19/26	60	220
100	24/29	60	220
250	19/26	82	270
250	24/29	82	270
500	24/29	107	310
500	29/32	107	310
1000	29/32	130	370

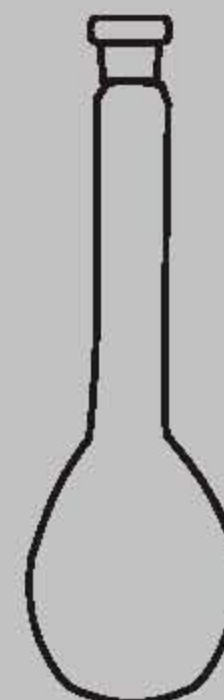

5021 REFRIGERENT LIEBIG CU ŞLIF

CONDENSER STRAIGHT SHAPE STANDARD GROUND MOUTH

Length of jacket (mm)	Ground mouth	Cooling area (dm ²)	Total length (mm)
80	10/19	0.16	165
80	14/23	0.16	175
150	14/23	0.6	254
200	14/23	1.0	305
200	19/26	1.0	332
200	24/29	1.0	350
200	29/32	1.0	360
300	19/26	1.6	432
300	24/29	1.6	450
300	29/32	1.6	460
400	19/26	2.1	535
400	24/29	2.1	555
400	29/32	2.1	560
500	19/26	2.7	632
500	24/29	2.7	650
500	29/32	2.7	660
600	19/26	3.2	735
600	24/29	3.2	735
600	29/32	3.2	760

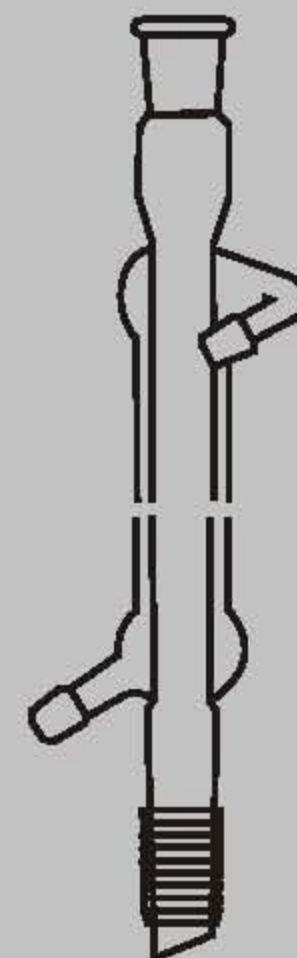

5021A REFRIGERENT DE AER CU ŞLIF

CONDENSER AIR COOLING STANDARD GROUND MOUTH



Lenght of jacket (mm)	Ground mouth	Cooling area (dm ²)	Total lenght (mm)
150	14/23	0.6	250
200	19/26	0.95	330
200	24/29	0.95	340
300	19/26	1.45	430
300	24/29	1.45	440
400	19/26	2.0	530
400	24/29	2.0	540
500	24/29	2.4	640

5022 REFRIGERENT CU BULE CU ŞLIF

CONDENSER WITH BULBED INNER TUBE STANDARD GROUND MOUTH

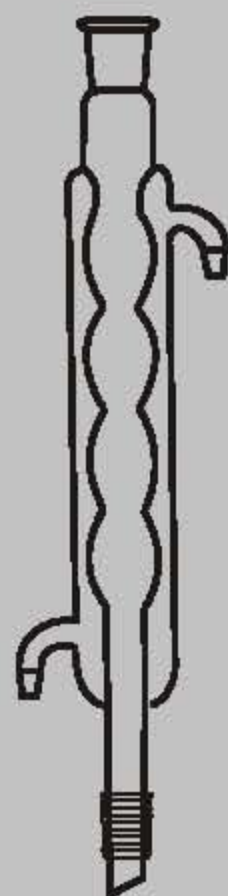

Lenght of jacket (mm)	Ground mouth	Cooling area (dm ²)	Total lenght (mm)
150	14/23	0.6	235
200	14/23	1.1	295
200	19/26	1.1	330
200	24/29	1.1	350
200	29/32	1.1	360
300	14/23	1.6	405
300	19/26	1.6	430
300	24/29	1.6	450
300	29/32	1.6	460
400	19/26	2.2	530
400	24/29	2.2	550
400	29/32	2.2	560
500	19/26	3.0	630
500	24/29	3.0	650
500	29/32	3.0	660
600	19/26	3.7	730
600	26/29	3.7	750
600	29/32	3.7	760

5023 REFRIGERENT CU SPIRALĂ CU ȘLIF

CONDENSEER WITH COILED INNER TUBE STANDARD GROUND MOUTH

Length of jacket (mm)	Ground mouth	Cooling area (dm ²)	Total length (mm)
150	14/23	1.2	235
200	14/23	2.3	295
200	19/26	2.3	330
200	24/29	2.3	350
300	19/26	3.5	430
300	24/29	3.5	450
300	29/32	3.5	460
400	19/26	4.7	530
400	24/29	4.7	550
400	29/32	4.7	560
500	19/26	5.7	630
500	24/29	5.7	650
500	29/32	5.7	660
600	19/26	7.7	730
600	26/29	7.7	750
600	29/32	7.7	760

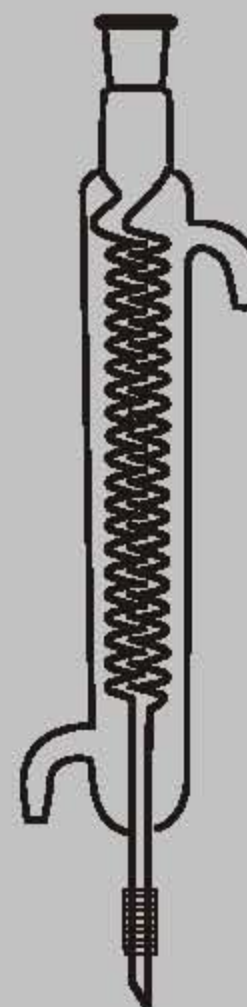

0197 PÂLNIE FILTRANTĂ CILINDRICĂ

FILTER FUNNELS CYLINDRICAL

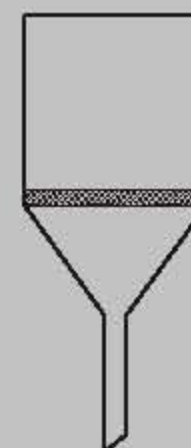

7101 LAME MICROSCOP

MICROSCOPE SLIDE GROUND EDGES

Size (mm)	Thickness (mm)
25.4 x 76.2 (1" x 3")	0.8 - 1.2

7201 LAMELE MICROSCOP

COVER GLASS

Size (mm)	Thickness (mm)
18 x 18	0.13 - 0.17
20 x 20	0.13 - 0.17
22 x 22	0.13 - 0.17
24 x 24	0.13 - 0.17

USTENSILE DE LABORATOR DIN PORȚELAN

0429 CAPSULĂ, SMĂLȚUITĂ PE PARTEA INTERIOARĂ EVAPORATING DISH



D. ext., mm	H. mm	V. ml
60	28	25
80	30	50
100	37	80
120	48	150
140	55	300
160	64	500
180	78	750
200	80	1000
300	95	2000



0430 MOJAR, SMĂLȚUIT 2/3 DIN PARTEA INTERIOARĂ MORTAR

D. ext., mm	H. mm	V. ml
60	35	25
100	55	110
130	65	220



0431 PISTIL PORȚELAN PESTLE ROUGH

H. mm

80
100
135

0432 CREUZET CU SMALȚ COMBUSTION CRUCIBLE



D. ext., mm	H. mm	V. ml
30	18	5
45	30	20
50	35	30
60	38	40
32	30	15
40	50	25
60	52	80